

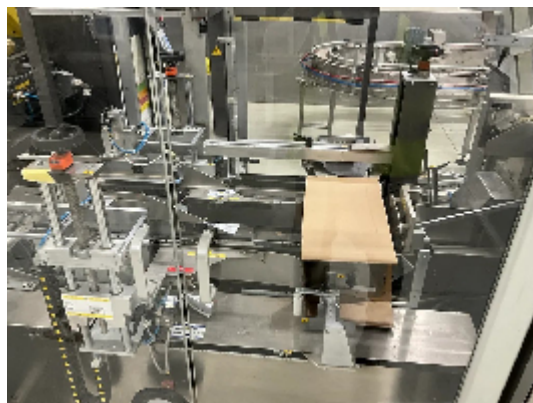

Cartoning Machines/Case packers IMA CP18+ FP (palletiser)

Images

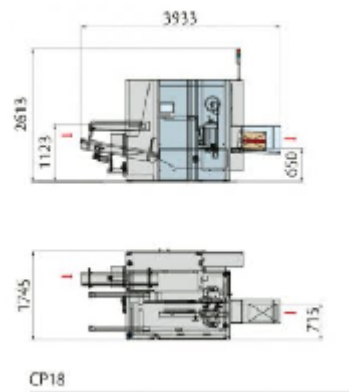

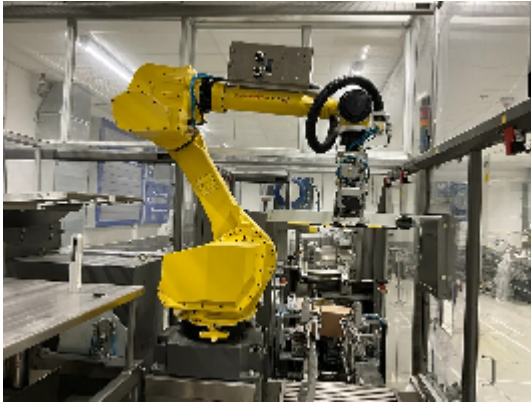

CP18 WORKFLOW

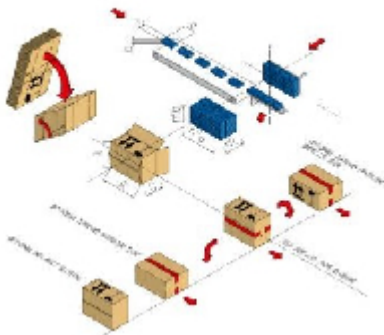

Product details

| | |
|----------------------|---------------------------------|
| Category: | Cartoning Machines/Case packers |
| Machine: | CP18+ FP (palletiser) |
| Machine code: | 23-1220 |

**Manufacturer:** IMA**Year of construction:** n/a

Description

case packer and palletiser IMA-UCINA Type CP18+ FP: extremely compact case packer with palletizing option. Ideal for packaging products such as pharmaceutical items, the machine is suitable for different production needs. Equipped with a horizontal case magazine for easy loading, the machine keeps the case erect during product insertion with the aid of suction cups fitted to the pick-up and forced opening arms. All the parts of the machine can be reached from the operator's side without having to walk to the opposite side to reach the carton stacking unit. The machine can be fitted with the following optional groups and features: case overturning, product tracking and camera detection devices, integrated labellers and markers, and can also be fully servo-driven.

1. Horizontal case magazine for easy loading.
2. All case flaps are positively closed and verified.
3. Case fully closed before transportation and taping.
4. Movable hopper to follow the cartons collation up into the case.
5. Suitable for Track & Trace purposes.
6. Further optional groups like liftable pusher to give total visibility of carton layer, labelling module, rejection system.
7. Possibility to be integrated with all Flex Palletizers.

Case dimensions

A B C

Min. 220 120 120

Max. 600 400 350

Casepacker output 8 cases/min.

Palletizer output up to 10 cycles/min.